

B AC Motors

Reversible Motor 40W(□90mm)

40W Reversible Motor 40W(□90mm)

Motor Specification

Model		Output W	Voltage V	Frequency Hz	Poles	Duty	Starting Torque		Rated Load			Capacitor μF / VAC	
Lead Wire Type	Terminal Box Type						kgfcm	N.m	Speed r/min	Current A	Torque kgfcm N.m		
9RDG*-40□(-T): Gear Type Shaft 9RDD*-40□(-T): D-Cut Type Shaft 9RDK*-40□(-T): Key Type Shaft													
9RDGA-40□	9RDGA-40□-T	40	1φ110	60	4	30min.	4.20	0.420	1600	1.25	2.60	0.260	16.0 / 250
9RDGD-40□	9RDGD-40□-T	40	1φ220	60	4	30min.	4.20	0.420	1600	0.61	2.60	0.260	4.0 / 450
9RDGE-40□	9RDGE-40□-T	40	1φ220	50	4	30min.	3.00	0.300	1350	0.36	3.00	0.300	3.0 / 450
			1φ240				3.60	0.360		0.39	3.40	0.340	

1) Enter the phase & voltage code in the place * and enter the model type of attaching Gearbox in the box (□) within the motor model name.

2) All models contain a built-in thermal protector.

3) Gear Type Shaft is for attaching Gearbox and D-Cut & Key Type Shafts are for using motor only.

Max. Permissible Torque at Output Shaft of Gearbox

60Hz

Motor Model	Gearbox Model	Gear Ratio	2	3	3.6	5	6	7.5	9	10	12.5	15	18	25	30	36	40	50	60	75	90	100	120	150	180	200
			r/min	900	600	500	360	300	240	200	180	144	120	100	72	60	50	45	36	30	24	20	18	15	12	10
9RDG□ -40G	9GBK□ BMH	kgfcm	4.3	6.5	7.8	10.8	12.9	16.2	19.4	21.6	27.0	32.4	35.1	48.8	58.5	63.6	70.7	88.4	100.0	100.0	100.0	100.0	100.0	100.0	100.0	100.0
		N.m	0.42	0.63	0.76	1.06	1.27	1.59	1.90	2.11	2.64	3.17	3.44	4.78	5.73	6.24	6.93	8.66	9.80	9.80	9.80	9.80	9.80	9.80	9.80	9.80

Motor Model	Gearbox Model	Gear Ratio	10	12	15	18	25	30	36	50	60
			r/min	180	150	120	100	72	60	50	36
9RDG□-40W	9WD□BL/□BR/ □BRL	kgfcm	21.3	25.0	30.0	34.6	45.5	51.5	59.9	78.0	85.8
		N.m	2.09	2.45	2.94	3.39	4.46	5.05	5.87	7.64	8.41

50Hz

Motor Model	Gearbox Model	Gear Ratio	2	3	3.6	5	6	7.5	9	10	12.5	15	18	25	30	36	40	50	60	75	90	100	120	150	180	200
			r/min	750	500	417	300	250	200	167	150	120	100	83	60	50	42	38	30	25	20	17	15	13	10	8
9RDG□ -40G	9GBK□ BMH	kgfcm	5.6	8.5	10.2	14.1	16.9	21.2	25.4	28.2	35.3	42.3	45.9	63.8	76.5	83.2	92.5	100.0	100.0	100.0	100.0	100.0	100.0	100.0	100.0	100.0
		N.m	0.55	0.83	1.00	1.38	1.66	2.07	2.49	2.77	3.46	4.15	4.50	6.25	7.50	8.16	9.06	9.80	9.80	9.80	9.80	9.80	9.80	9.80	9.80	9.80

Motor Model	Gearbox Model	Gear Ratio	10	12	15	18	25	30	36	50	60
			r/min	150	125	100	83	60	50	42	30
9RDG□-40W	9WD□BL/□BR/ □BRL	kgfcm	27.9	32.6	39.3	45.3	59.5	67.3	78.3	102.0	112.2
		N.m	2.73	3.20	3.85	4.44	5.83	6.60	7.68	10.00	11.00

1) Enter the phase & voltage code in the box (□) within the motor model name.

2) Enter the gear ratio in the box (□) within the Gearbox model name.

3) A colored background indicates gear shaft rotation in the same direction as the motor shaft; a white background indicates rotation in the opposite direction.

4) The rotating speed is calculated by dividing the motor's synchronous speed (50Hz: 1,500r/min, 60Hz: 1,800r/min) by the gear ratio. The actual speed is 2~20% less than the displayed value, depending on the size of the load.

Dimensions

MOTOR ONLY

- MOTOR MODEL: 9RDD□-40(-T) (NO FAN)

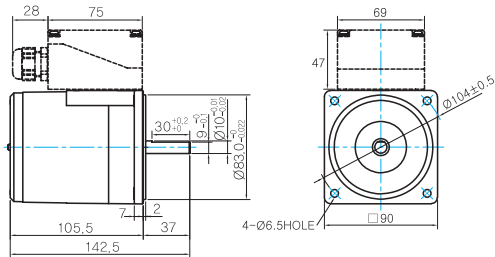

MOTOR OUTPUT SHAFT

MODEL	SPEC
D-CUT TYPE	
KEY TYPE	

INTER-DECIMAL GEARBOX

- MODEL: 9XD10□□

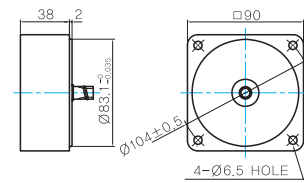

GEARED MOTOR

G TYPE GEARBOX

- MOTOR MODEL: 9RDG□-40G (NO FAN)
- GEARBOX MODEL: 9GBK□BMH

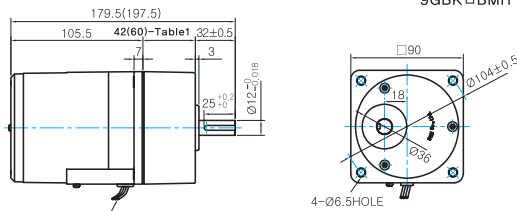

LEAD WIRE 300mm
UL STYLE NO.3271 AWG NO.22

GEARBOX OUTPUT SHAFT

MODEL	SPEC
KEY TYPE	

KEY SPEC

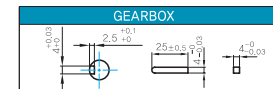

- 42(60)-Table1

SIZE(mm)	GEAR RATIO
42	9GBK2BMH - 9GBK18BMH
60	9GBK25BMH - 9GBK200BMH

W TYPE GEARBOX

- MOTOR MODEL: 9RDG□-40W (NO FAN)
- GEARBOX MODEL: 9WD□BL/BR/BRL

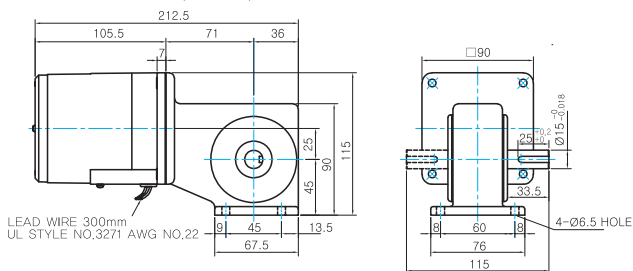

LEAD WIRE 300mm
UL STYLE NO.3271 AWG NO.22

KEY SPEC

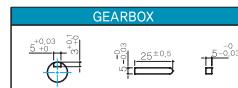

WEIGHT

PART	WEIGHT(Kg)	
MOTOR	2.4	
GEAR BOX	9GBK2BMH ~ 9GBK15BMH	0.67
	9GBK18BMH ~ 9GBK30BMH	0.96
	9GBK36BMH ~ 9GBK200BMH	1.07
	9WD□BL/BR/BRL	1.0
9XD10□□	0.5	

B AC Motors

Reversible Motor 40W(□90mm)

Motor Images

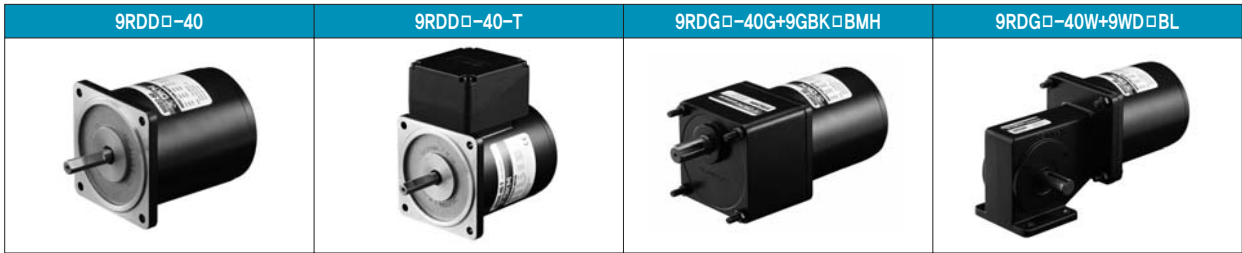

Connection Diagrams

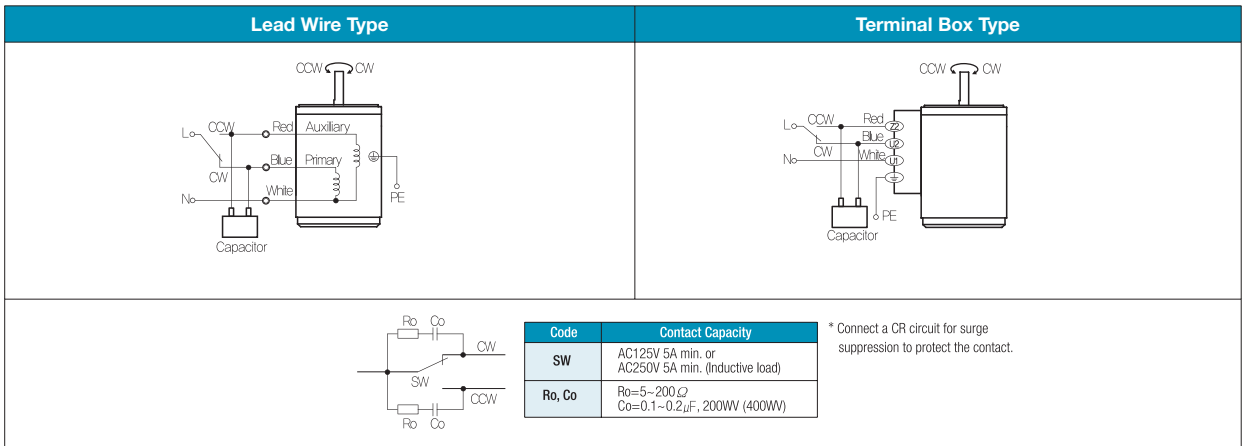

- 1) The direction of motor rotation is as viewed from the shaft end of the motor.
- 2) CW represents the clockwise direction, while CCW represents the counterclockwise direction.
- 3) During operation it is available to change the rotating direction by turning the switch to CW or CCW.